

# The E-Cell™ System

## The E-Cell™ Solution

E-Cell™ is a revolution in chemical-free deionization. E-Cell™'s robust, modular electrodeionization (EDI) technology is cost-effective for all flow rates.

- No regeneration chemicals
- No hazardous waste stream
- Simple, continuous operation
- Reduced facility requirements
- Flow rates up to 2000 gpm (450 m<sup>3</sup>/h) and beyond

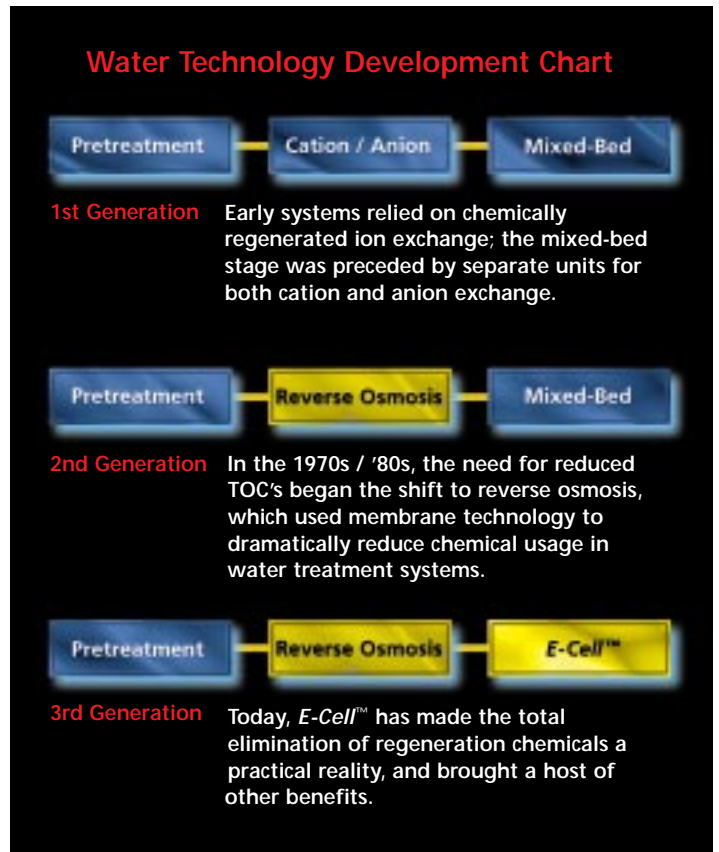

### Six Standard Systems

Using the six standard E-Cell Systems™, you can configure any size installation to meet your flow requirements. You can also design E-Cell Systems™ using the 12.5 gpm (3 m<sup>3</sup>/h) stack, from the ground up incorporating your own design specifications.



25 gpm (6 m<sup>3</sup>/h)



50 gpm (11 m<sup>3</sup>/h)



100 gpm (23 m<sup>3</sup>/h)



150 gpm (34 m<sup>3</sup>/h)



200 gpm (45 m<sup>3</sup>/h)



300 gpm (68 m<sup>3</sup>/h)

# How does E-Cell™ Work?

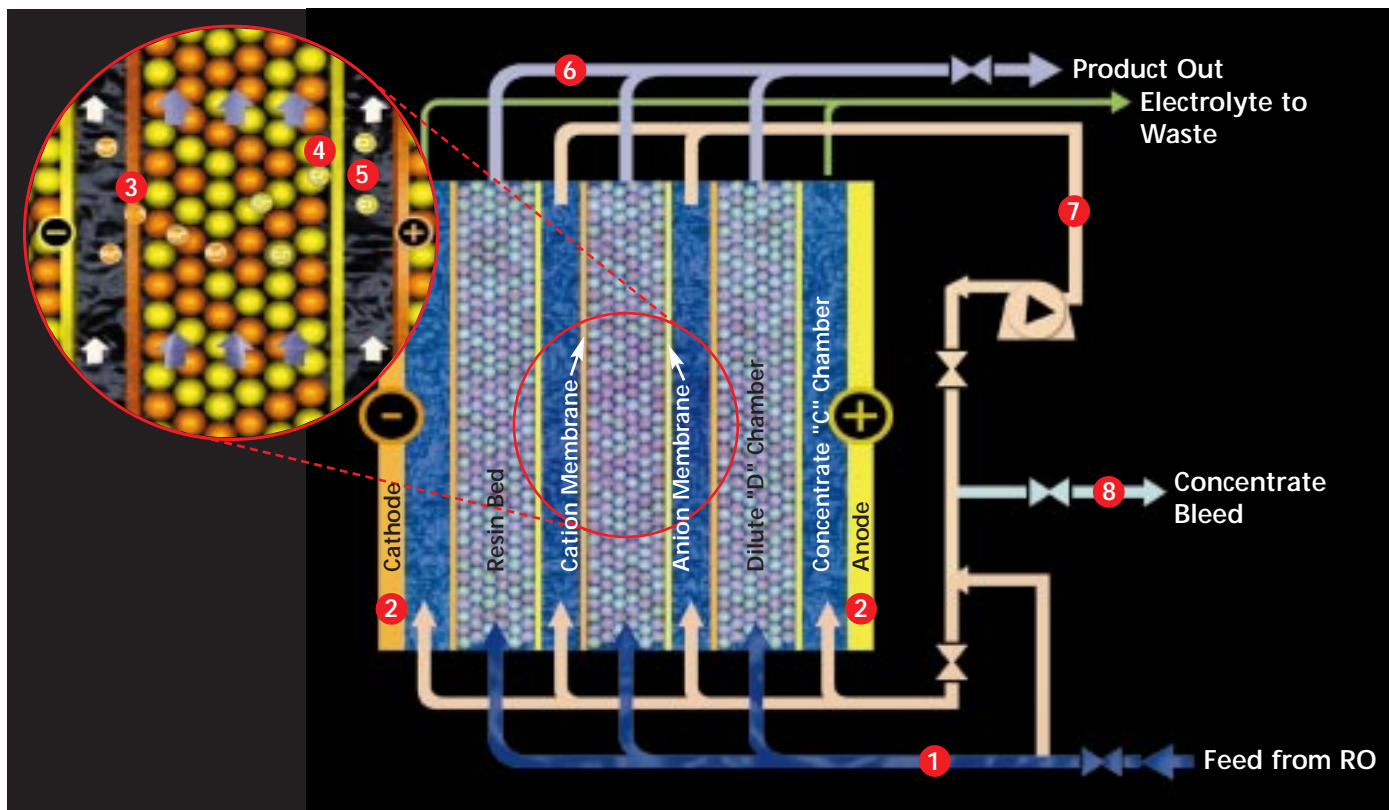

- 1 Feed water enters the E-Cell™ stack and is diverted into a series of cells.
- 2 A DC charge is applied across the cell, splitting water molecules in the "D" Chamber into hydrogen and hydroxyl ions.
- 3 Hydrogen and hydroxyl ions are drawn through the cation and anion membranes into the "C" Chamber according to their charges. The production and migration of these ions continuously regenerates the resin bed.
- 4 Contaminant ions, such as silicon, chlorine and TOCs attach to their respective ion-exchange resins and join the migration into the "C" Chamber.
- 5 In the "C" Chamber, hydrogen and hydroxyl ions combine to yield water.
- 6 Up to 95% of the feed water is deionized and exits through the "D" Chamber.
- 7 Concentrate water is recirculated to achieve higher flow velocity through the stack, improving performance and promoting mixing.
- 8 With a pH in the range of 5 to 8, water saturated with contaminant ions is "bled off" and can either be discharged to drain or reinjected into the system ahead of Pretreatment.

## Feed Water Requirements

Constituent	US Units	Metric Units	Range
TEA including CO <sub>2</sub>	ppm CaCO <sub>3</sub>	mg/l CaCO <sub>3</sub>	<25.0
pH			5.0 to 9.0
Hardness	ppm CaCO <sub>3</sub>	mg/l CaCO <sub>3</sub>	<1.0

## E-CELL™

E-Cell Corporation

52 Royal Road, Guelph, Ontario, Canada N1H 1G3

Tel: +1 (519) 836-2260 x521 Fax: +1 (519) 836-0982 Toll Free: 1 (888) 386-5132 (USA and Canada)

Website: [www.ecell.com](http://www.ecell.com) E-mail: [ecell@ecell.com](mailto:ecell@ecell.com)

